

BGM

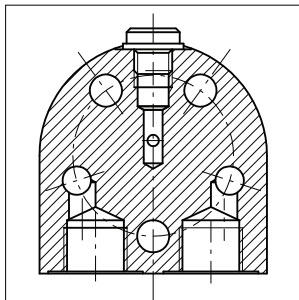

MOTORI ORBITALI

ORBITAL MOTORS

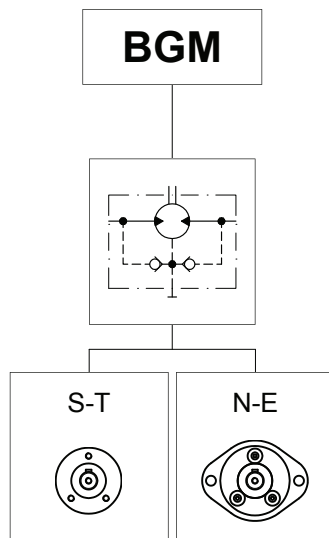

Alimentazione laterale.
Side ports configuration.

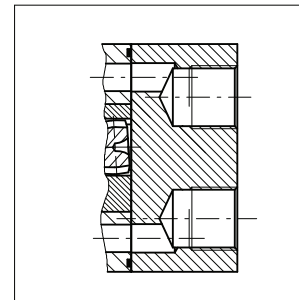

Alimentazione posteriore.
Rear ports configuration.

Buone capacità di carico radiale e assiale.
Very good side and axial load capacity.

Possibilità di alimentazione laterale o posteriore.
Rear and side ports option.

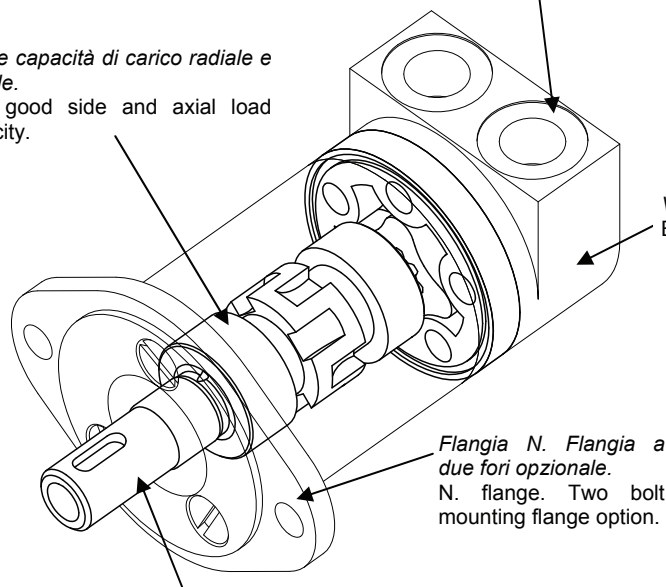

Valvole interne di drenaggio.
Built-in check valves.

Flangia N. Flangia a due fori opzionale.
N. flange. Two bolt mounting flange option.

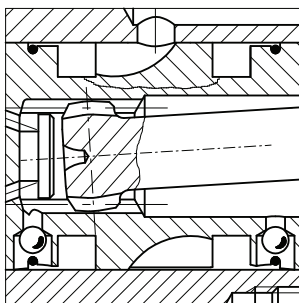

Distribuzione radiale e tolleranze ridotte al minimo per assicurare un drenaggio ridotto - Valvole interne di drenaggio.
Optimized spool valve design to minimize the leakage - built-in check valves.

Elevato rapporto coppia/peso e buona regolarità a basso numero di giri.
High torque/weight ratio and very good low speed performance.

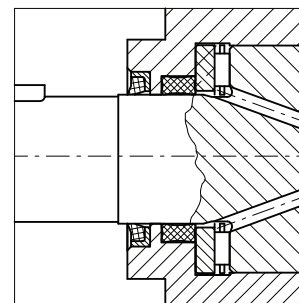

Parapolvere per proteggere la guarnizione di tenuta dell'albero dalle impurità.
Dust seal to protect the high pressure shaft seal.

CARATTERISTICHE TECNICHE TECHNICAL SPECIFICATIONS

Motore Motor	Cilindrata Displacement cm ³ /giro [in ³ /rev]	Max. pressione in ingresso Max. input pressure bar [psi]	Pressione diff. max. Max. differential pressure bar [psi]	Coppia max.* Max. torque*	Portata max. Max. flow	Velocità max. Max. speed	Potenza max. Max. power
		Cont Int ¹⁾ Peak ²⁾	Cont Int ¹⁾ Peak ²⁾	Cont Int ¹⁾ Peak ²⁾	Cont Int ¹⁾ Peak ²⁾	Cont Int ¹⁾ Peak ²⁾	Cont Int ¹⁾ Peak ²⁾
BGM 013	12.9 [0.78]	140 [2030] 175 [2537] 225 [3265]	100 [1450] 140 [2030] 200 [2900]	16 [11.7] 23 [16.9] 33 [24.3]	20 [5.28] 25 [6.60]	1550 1935	2.3 [3.08] 3.2 [4.28]
BGM 020	20 [1.22]	140 [2030] 175 [2537] 225 [3265]	100 [1450] 140 [2030] 200 [2900]	25 [18.4] 35 [25.7] 51 [37.5]	20 [5.28] 25 [6.60]	1000 1250	2.3 [3.08] 3.3 [4.42]
BGM 032	31.8 [1.93]	140 [2030] 175 [2537] 225 [3265]	100 [1450] 140 [2030] 160 [2320]	39 [28.7] 54 [39.7] 60 [44.2]	20 [5.28] 25 [6.60]	625 785	2.3 [3.08] 2.8 [3.75]
BGM 040	40.1 [2.44]	140 [2030] 175 [2537] 225 [3265]	100 [1450] 140 [2030] 160 [2320]	50 [36.8] 67 [49.3] 76 [56.0]	20 [5.28] 25 [6.60]	495 620	1.8 [2.41] 2.5 [3.35]
BGM 050	50 [3.05]	140 [2030] 175 [2537] 225 [3265]	80 [1160] 140 [2030] 160 [2320]	49 [36.1] 83 [61.1] 94 [69.2]	20 [5.28] 25 [6.60]	400 500	1.8 [2.41] 2.4 [3.21]

¹⁾ Le condizioni intermittenti non devono durare più del 10% di ogni minuto / Intermittent duty must not exceed 10% each minute.

²⁾ Le condizioni di picco non devono durare più del 1% di ogni minuto / Peak duty must not exceed 1% each minute.

Motore Motor	Pressione max scar. con drenaggio Max return pressure with drain line bar [psi]	Pressione max avviamento a vuoto Max starting pressure with no load bar [psi]	Coppia minima di spunto Min starting torque Nm [lbf-ft]
BGM 013	140 [2030]	4 [58]	A press. diff. Max At max Δp Cont Int ¹⁾ 12 [8.8] 17 [12.5]
BGM 020	140 [2030]	4 [58]	A press. diff. Max At max Δp Cont Int ¹⁾ 21 [15.4] 30 [22.1]
BGM 032	140 [2030]	4 [58]	A press. diff. Max At max Δp Cont Int ¹⁾ 35 [25.7] 51 [37.5]
BGM 040	140 [2030]	4 [58]	A press. diff. Max At max Δp Cont Int ¹⁾ 34 [25] 48 [35.3]
BGM 050	140 [2030]	4 [58]	A press. diff. Max At max Δp Cont Int ¹⁾ 40 [29.4] 70 [51.5]

MASSIMA PRESSIONE AMMESSA SULLA GUARNIZIONE ALBERO MAX PERMISSIBLE SHAFT SEAL PRESSURE

Pressione massima di scarico senza drenaggio o massima pressione nella linea di drenaggio. I motori sono forniti nella versione con guarnizioni standard (diagramma Standard) o nella versione con guarnizioni ad alta pressione (diagramma HPS). Per condizioni di pressione e velocità non contemplate dal presente grafico si consiglia di contattare la S.A.M. Hydraulik.

Max. return pressure without drain line or max. pressure in the drain line. Motor are supplied in standard seal version (Standard chart) or in HPS seal version (HPS chart). For pressure and speeds not showed in the curve below, please contact S.A.M. Hydraulik.

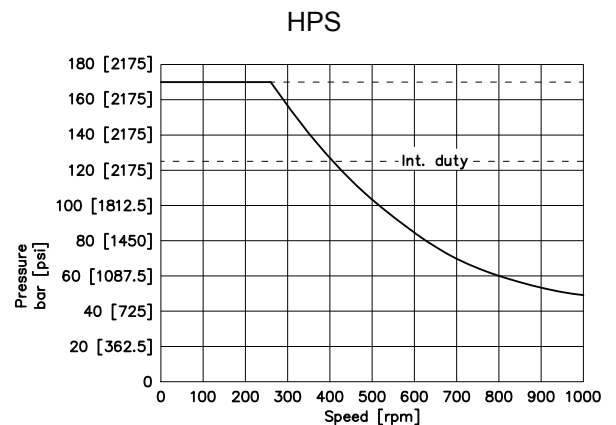
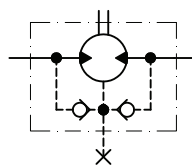
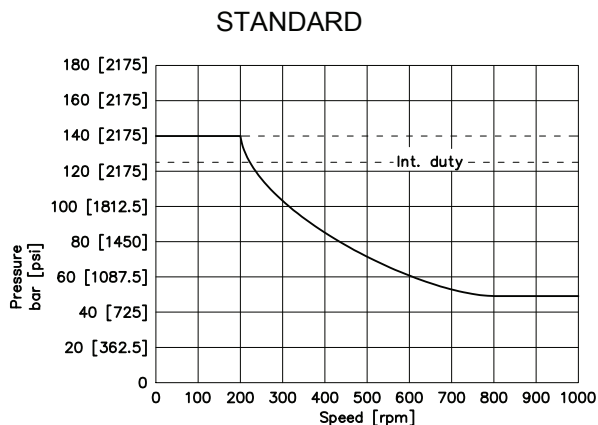

PERDITE DI CARICO PER ATTRAVERSAMENTO PRESSURE LOSS

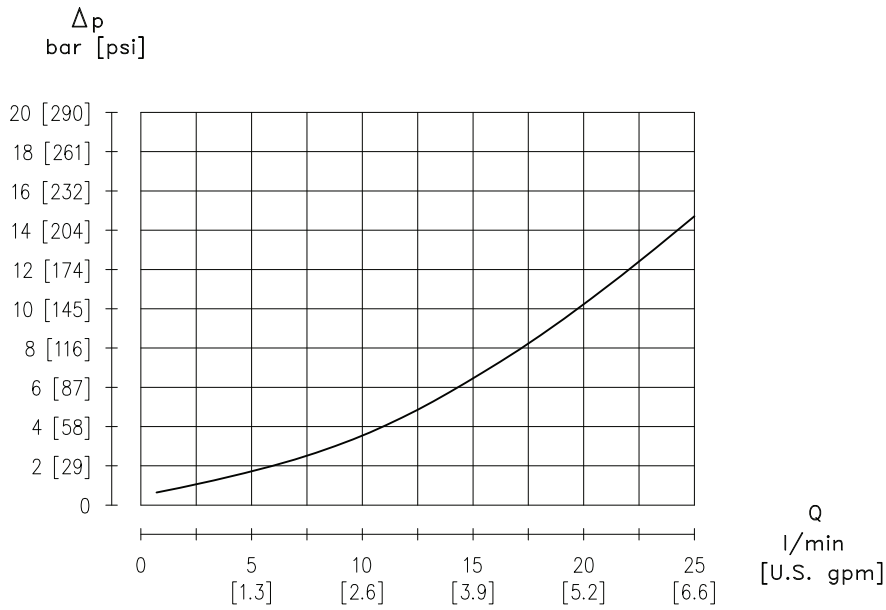

Il diagramma è stato ottenuto con prove eseguite su un numero significativo di motori, utilizzando un'olio avente una viscosità cinematica di 37 cSt alla temperatura di 45° C.

Diagram according to tests done with a relevant number of motors and using hydraulic oil with kinematic viscosity of 37 cSt at 45° C temperature.

CODICE DI ORDINAZIONE ORDERING CODE

Le seguenti lettere o numeri del codice, sono state sviluppate per identificare tutte le configurazioni possibili dei motori BGM. Usare il seguente modulo per identificare le caratteristiche desiderate. **Tutte le lettere o numeri del codice devono comparire in fase d'ordine.** Si consiglia di leggere attentamente il catalogo prima di iniziare la compilazione del codice di ordinazione.

The following alphanumeric digits system has been developed to identify all of the configuration options for the BGM motors. Use the model code below to specify the desired features. **All alphanumeric digits system of the code must be present when ordering.** We recommend to carefully read the catalogue before filling the ordering code.

CODICE PRODOTTO / MODEL CODE

1	2	3	4	5	6	7	8	8A	9	10

1 - SERIE / SERIES

BGM	Motore orbitale Orbital motor
-----	----------------------------------

2 - FLANGIA / FLANGE

S	3 fori M6 - Ø31.5mm 3 bolts M6 - Ø31.5mm [Ø 1.240 in]	STANDARD
T	3 fori 1/4 - 28 UNF - Ø31.5mm 3 bolts 1/4 - 28 UNF - Ø31.5mm [Ø 1.240 in]	
N	2 fori - Ø63mm (In abbinamento con flangia S) 2 bolts - Ø63mm [Ø 2.480 in] - (combination with S flange)	
E	2 fori - Ø63mm - (In abbinamento con flangia T) 2 bolts - Ø63mm [Ø 2.480 in] - (combination with T flange)	

3 - CILINDRATA / DISPLACEMENT

013	12.9 cm ³ /giro [0.78 in ³ /rev]
020	20 cm ³ /giro [1.22 in ³ /rev]
032	31.8 cm ³ /giro [1.93 in ³ /rev]
040	40.1 cm ³ /giro [2.44 in ³ /rev]
050	50 cm ³ /giro [3.05 in ³ /rev]

4 - COPERCHIO / COVER

FR0	Versione Base Standard Version
SP1	Versione SP1 SP1 Version
FRQ	Versione Q Q Version

5 - ATTACCHI / MAIN PORTS

		COPERCHIO / COVER		
		FR0	SP1	FRQ
M06	Attacchi 3/8 G (BSPP) 3/8 G (BSPP) Main Ports	STANDARD	•	•
S06	Attacchi 9/16 - 18 UNF 9/16 - 18 UNF Main Ports		•	/

• Disponibile - Available / Non Disponibile - Not Available

1	2	3	4	5	6	7	8	8A	9	10

6 - ESTREMITÀ ALBERO / SHAFT END

CL160	Cilindrico Ø16 mm Parallel keyed Ø16 mm [0.629 in]
SC160	Scanalato profilo B17x14 DIN5482 B17x14 DIN5482 Splined
CL158	Cilindrico Ø15.88 mm Parallel keyed Ø15.88 mm [Ø0.625 in]
CS158	Cilindrico crosshole Ø15.88 mm Parallel crosshole Ø15.88 mm [Ø0.625 in]

7 - TENUTE / SEALS

N	NBR
---	-----

8 - VALVOLE / VALVES

		ATTACCHI / MAIN PORTS	
		M06	S06
XXXX	Non Richieste Not Required	•	•
M061	Valvola di massima pressione VAF 06 - D Pressure relief valve VAF 06 - D	•	/

- Disponibile - Available / Non Disponibile - Not Available Per le caratteristiche vedere il catalogo valvole
For the feature see catalogue valves

8A - CARATTERISTICA VALVOLA / VALVES FEATURE

		VALVOLE / VALVES	
		XXXX	M061
000	Caratteristica non necessaria Feature not necessary	•	/
001	Non Tarata (Campo Taratura 50÷150 bar) Not Set 50÷150 bar [725 to 2175 psi]	/	•

- Disponibile - Available / Non Disponibile - Not Available Per la fornitura di valvole tarate contattare Uff. Tecnico.
Please contact Technical department for valve which require specific setting

9 - CARATTERISTICHE SPECIALI / SPECIAL FEATURE

		FLANGIA / FLANGE		
		S	T	N
XXX	Versione Base Standard version	•	•	•
HPS	Guarnizione alta pressione High Pressure Seal	•	•	•
TES	Tachimetro TAC-E (con predisposizione per sensore) - Senso di rotazione impiego SX (Standard) TAC-E Tachometer (with sensor arrangement) - CCW suitable direction of rotation (Standard)	•	/	•
TED	Tachimetro TAC-E (con predisposizione per sensore) - Senso di rotazione impiego DX (Opzionale) TAC-E Tachometer (with sensor arrangement) - CW suitable direction of rotation (Optional)	•	/	•

- Disponibile - Available / Non Disponibile - Not Available

10 - OPZIONI / OPTIONS

XX	Non Verniciato Not Painted
01	Verniciato Nero RAL 9005 Black Painted RAL 9005

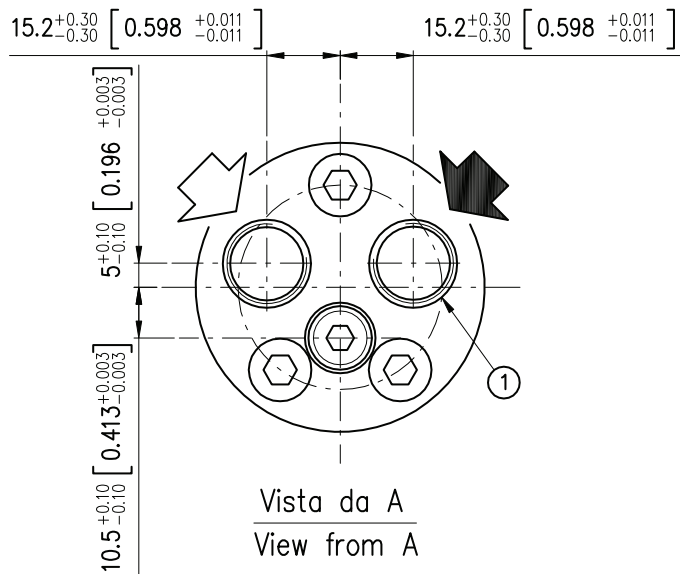
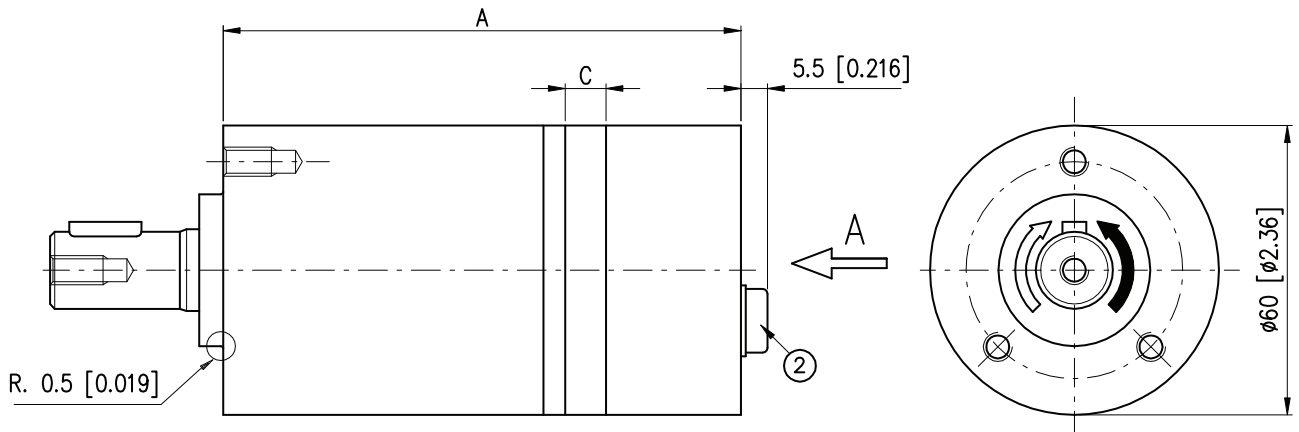

ATTACCHI M06 / M06 MAIN PORTS

- 1) N.2 Fori di alimentazione 3/8 G (BSPP) prof. filetto 12mm
N.2 3/8 G (BSPP) main ports thread depth [0.472 in]
- 2) Drenaggio motore 1/8 G (BSPP) prof. filetto 9mm
1/8 G (BSPP) drain port thread depth [0.354 in]

ATTACCHI S06 / S06 MAIN PORTS

- 1) N.2 Fori di alimentazione 9/16"-18 UNF prof. filetto 13mm
N.2 9/16"-18 UNF main ports thread depth [0.511 in]
- 2) Drenaggio motore 7/16"-20 UNF prof. filetto 12mm
7/16"-20 UNF drain port thread depth [0.472 in]

		BGM 013	BGM 020	BGM 032	BGM 040	BGM 050
A	mm [in]	104.5 [4.11]	107.5 [4.23]	112.5 [4.42]	116 [4.56]	120 [4.72]
B	mm [in]	-	-	-	-	-
C	mm [in]	5.5 [0.216]	8.5 [0.334]	13.5 [0.531]	17 [0.66]	21 [0.82]
Pesi - Weight	kg [lb]	2 [4.4]	2.06 [4.5]	2.15 [4.7]	2.2 [4.8]	2.25 [4.9]

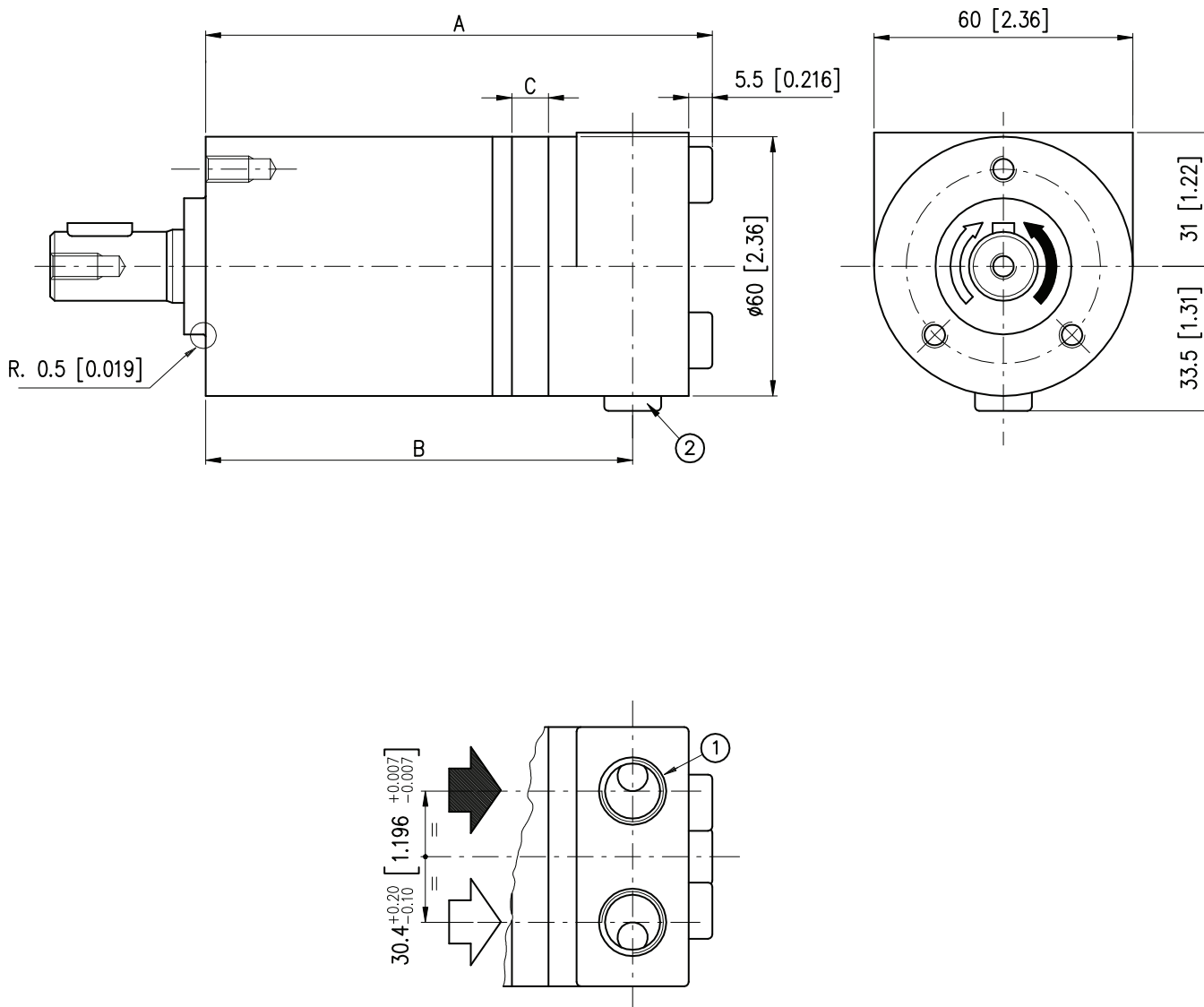

ATTACCHI M06 / M06 MAIN PORTS

- 1) N.2 Fori di alimentazione 3/8 G (BSPP) prof. filetto 12mm
N.2 3/8 G (BSPP) main ports thread depth [0.472 in]
- 2) Drenaggio motore 1/8 G (BSPP) prof. filetto 10mm
1/8 G (BSPP) drain port thread depth [0.393 in]

ATTACCHI S06 / S06 MAIN PORTS

- 1) N.2 Fori di alimentazione 9/16"-18 UNF prof. filetto 13mm
N.2 9/16"-18 UNF main ports thread depth [0.511 in]
- 2) Drenaggio motore 7/16"-20 UNF prof. filetto 12mm
7/16"-20 UNF drain port thread depth [0.472 in]

		BGM 013	BGM 020	BGM 032	BGM 040	BGM 050
A	mm [in]	113.8 [4.48]	116.8 [4.59]	121.8 [4.79]	125.3 [4.93]	129.3 [5.09]
B	mm [in]	95.3 [3.75]	98.3 [3.87]	103.3 [4.06]	106.8 [4.20]	110.8 [4.36]
C	mm [in]	5.5 [0.216]	8.5 [0.334]	13.5 [0.531]	17 [0.66]	21 [0.82]
Pesi - Weight	kg [lb]	2.1 [4.6]	2.16 [4.7]	2.25 [4.9]	2.3 [5]	2.35 [5.1]

Flangia S Flange

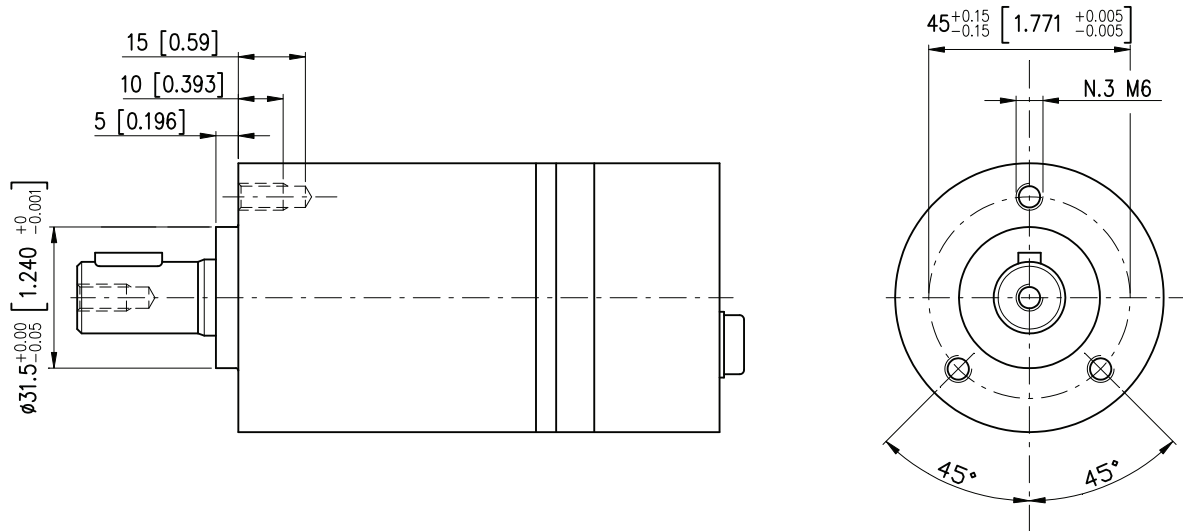

Flangia T Flange

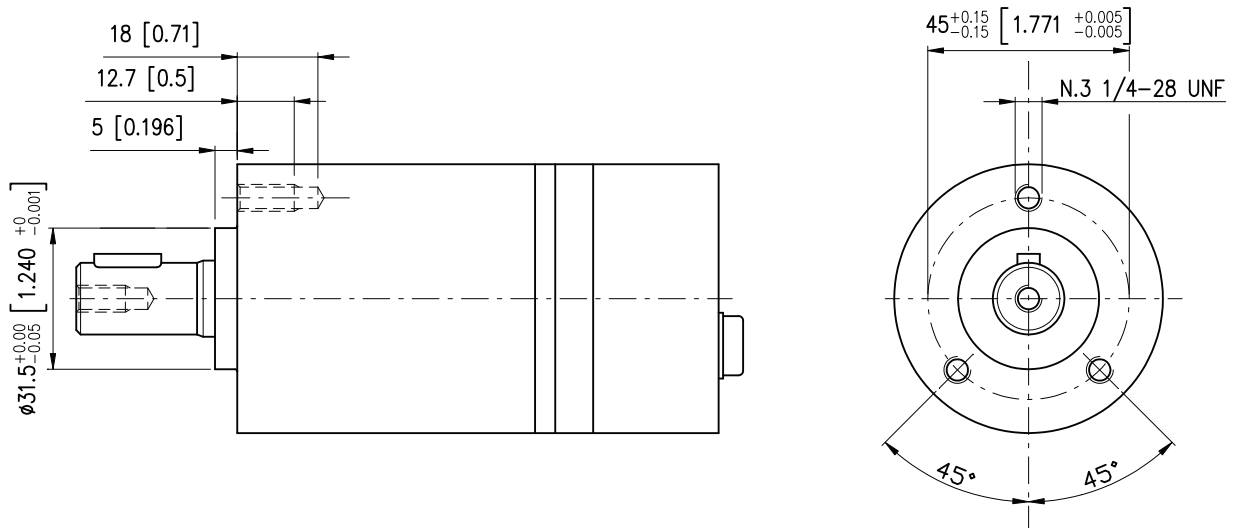

Flangia N - E Flange

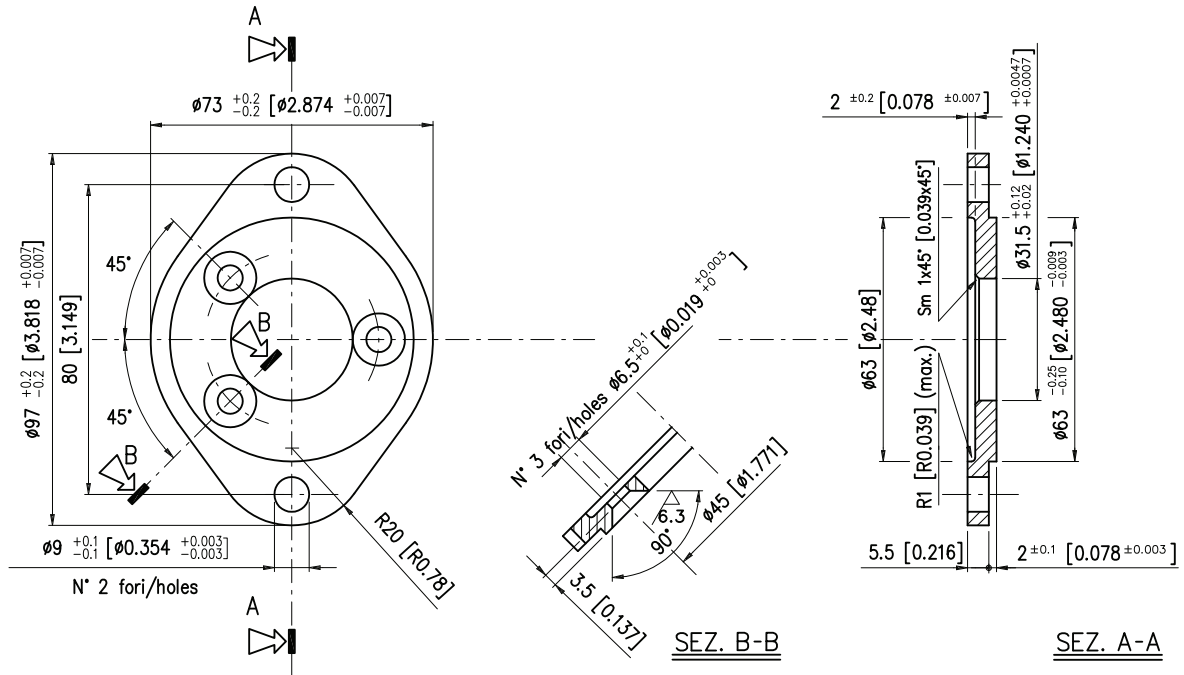

Montaggio flangia / Flange assembling

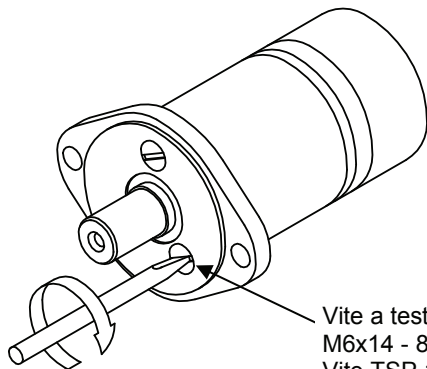

- Vite a testa svasata piana con tagli M6x14 - 8.8 UNI 7688 (con flangia S).
- M6x14 - 8.8 UNI 7688 flathead screw (with S flange).
- Vite TSP 1/4-28 UNF 1/2" - 8.8 DIN 965 screw (con flangia T)
- TSP 1/4-28 UNF 1/2" - 8.8 DIN 965 screw (with T flange)

ALBERO CILINDRICO CL160
CL160 CYLINDRICAL SHAFT

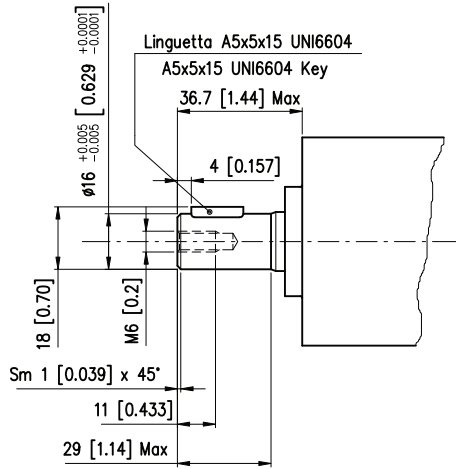

Coppia Massima 39Nm
Max Torque Continuous 39Nm [28.743 lbf·ft]

ALBERO SCANALATO SC160
SC160 SPLINED SHAFT

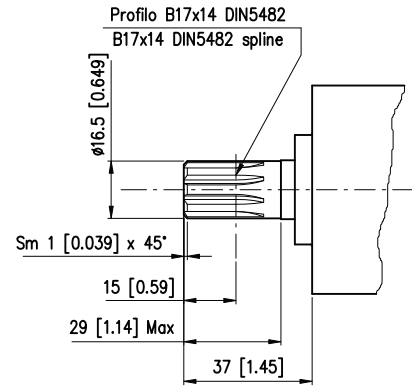

Coppia Massima 44Nm
Max Torque Continuous 44Nm [32.428 lbf·ft]

ALBERO CILINDRICO CL158
CL158 CYLINDRICAL SHAFT

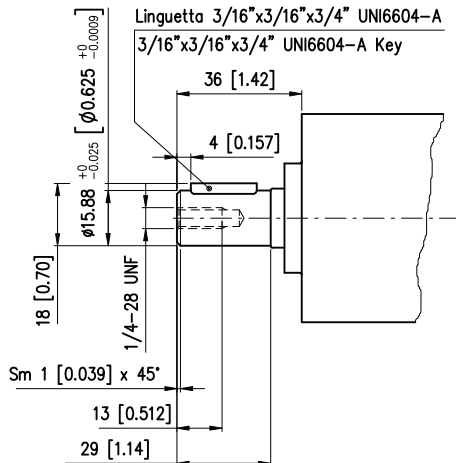

Coppia Massima 39Nm
Max Torque Continuous 39Nm [28.743 lbf·ft]

ALBERO CILINDRICO CROSSHOLE CS158
CS158 CYLINDRICAL CROSSHOLE SHAFT

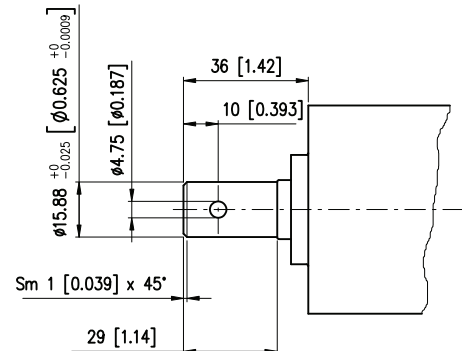

Coppia Massima 39Nm
Max Torque Continuous 39Nm [28.743 lbf·ft]

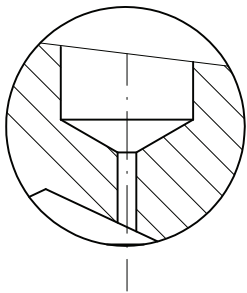
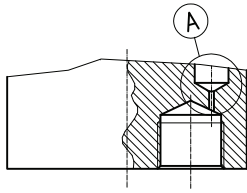

PART. A
Strozzatore fisso
Flow restrictor

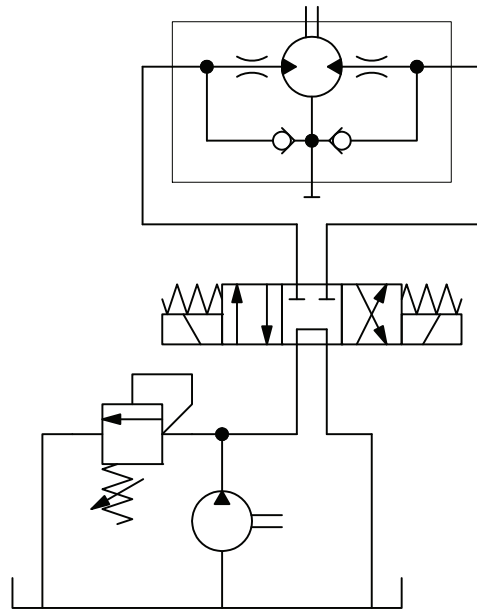

I motori BGM/FRQ dispongono di uno strozzatore sulla parte posteriore del motore che assicura velocità molto basse dell'albero anche in presenza di valori elevati di portata. Una tipica applicazione è quella della rotazione dei tubi di scarico delle turbine da neve montate su autocarri o trattori.

BGM/FRQ motors feature a restrictor at the back of the motor meant to ensure very low shaft speed though in presence of high flow. Typical applications are truck or tractor mounted snow blowers.

CURVE CARATTERISTICHE
PERFORMANCE CURVES

BGM...FRQ

Curva caratteristica della coppia (Nm) in funzione del numero di giri per le diverse pressioni di taratura della valvola a monte della strozzatura con foro $D = 1.2 \text{ mm}$ su motore BGM32.

Performance curves (torque/speed) according to pressure relief valve setting and 1.2 mm [0.047 in] diameter (for BGM32) of flow restrictor.

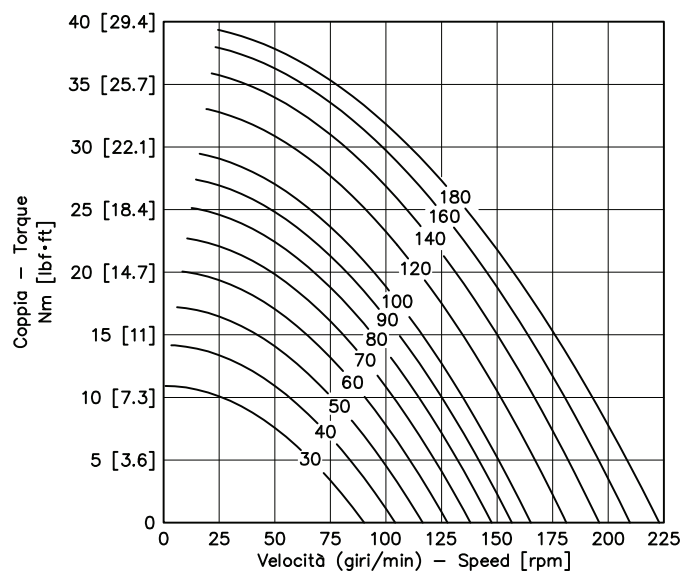

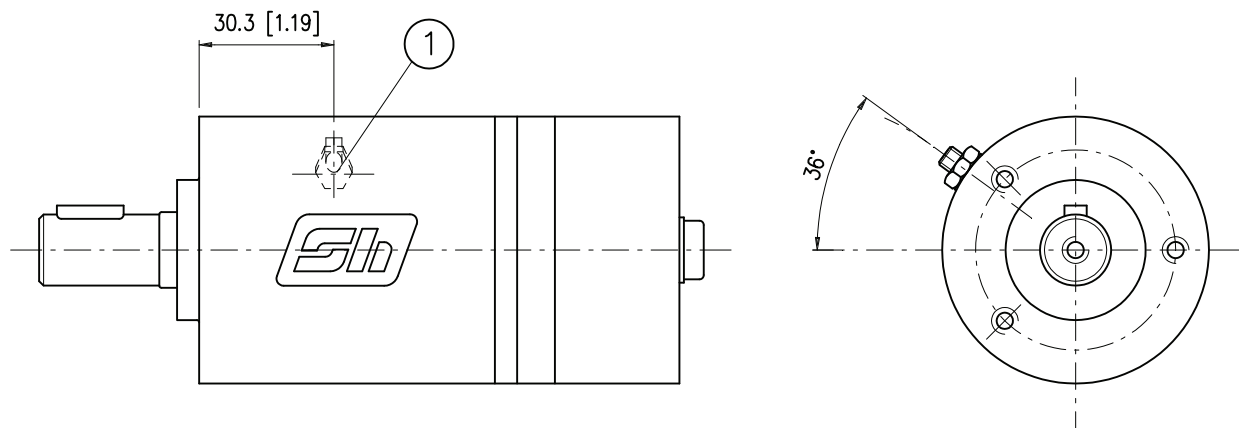

- 1) *Attacco sensore M5x0.5*
Sensor connection M5x0.5

**KIT SENSORE
SENSOR KIT**

1. *Cod. 424.0090.0000*
Sensore induttivo (1A) + dado di fissaggio
M5x0.5 (1B)
2. *Cod. 406.0730.0000*
Rondella di tenuta GM2000 M5

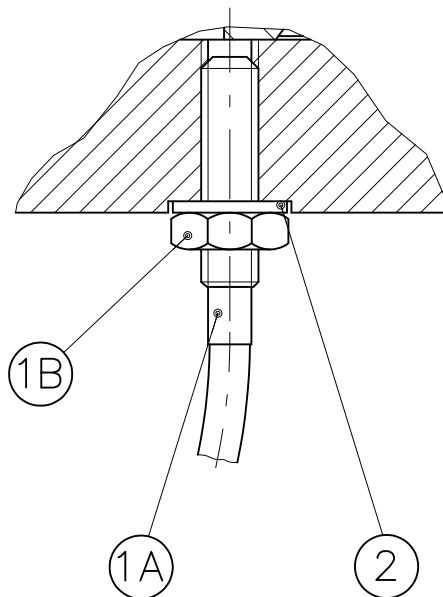

1. *Cod. 424.0090.0000*
inductive sensor (1A) + M5x0.5
locking nut (1B)
2. *Cod. 406.0730.0000*
Sealing washer GM2000 M5

Caratteristiche sensore elettronico

Numero d'impulsi per giro = 4
 Principio di funzionamento induttivo
 Funzione di uscita PNP
 Tensione nominale 10-30 V d.c.
 Caricabilità massima 200 mA
 Frequenza massima 3000 Hz
 Campo di temperatura -25° C +85° C
 Gradi di protezione IP 67
 Lunghezza cavo 2 m

**Segnale di uscita in versione elettronica
Output signal electronic tachometer**

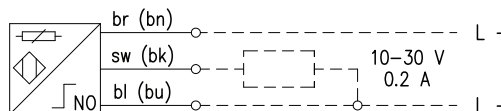
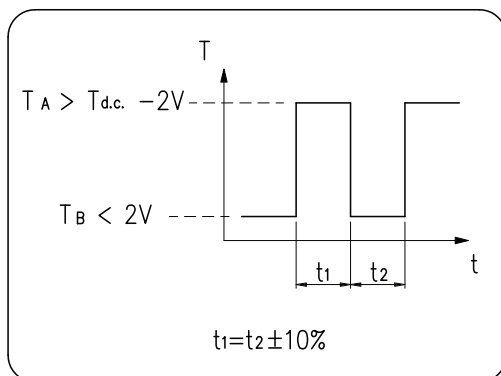

Electronic sensor technical features

Number of pulses for revolution = 4
 Inductive principle
 Output current PNP
 Voltage 10-30 V d.c.
 Max load 200 mA
 Max frequency 3000 Hz
 Temperature range -25°C +85°C
 Enclosure IP 67
 Cable length 2 m

**SENSO DI ROTAZIONE OTTIMALE
PREFERENTIAL DIRECTION OF ROTATION**

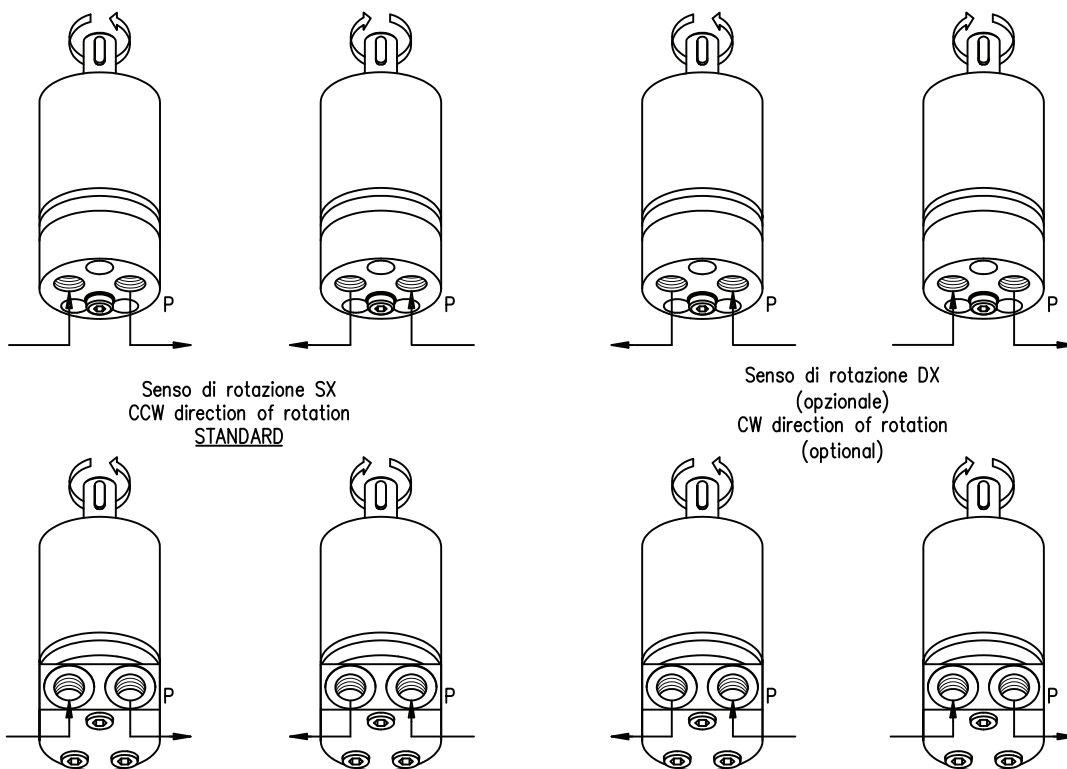

Si consiglia l'impiego della versione SX o DX in funzione del senso di rotazione prevalente del motore, al fine di sottoporre il sensore alla pressione tendenzialmente più bassa.

The selection of the version CW or CCW depends on the prevailing direction of rotation of the motor, in order to use the sensor at the lower working pressure.

CARICHI AMMESSI SULL'ALBERO SHAFT LOAD CAPACITY

Il carico radiale ammissibile dipende da

- Velocità (n)
- Distanza (L) del punto di carico dalla flangia

The permissible radial shaft load depends on

- Speed (n)
- Distance (L) from the point of load to the mounting flange

Formula utilizzabile per il calcolo del carico radiale (P_r) ai vari numeri di giri e alle varie distanze dalla flangia

Radial load capacity (P_r) curve according to speed (n) and distance (L) from flange

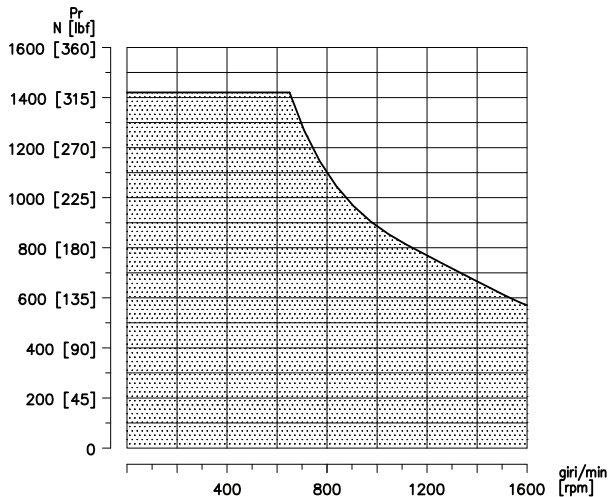

$$P_r = \frac{1500}{n} \cdot \frac{52300}{55.5 + L} \quad (N)$$

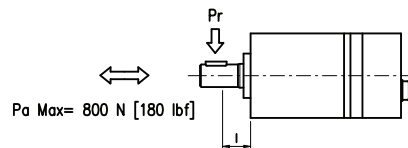

Formula valida per $n \geq 650$ rpm
Per $n < 650$ rpm $P_{rmax} = 1450$ N

This formula being valid for $n \geq 650$ rpm
For $n < 650$ rpm $P_{rmax} = 1450$ N [326.25 lbf]

La curva mostra la relazione tra (P_r) e (n)

The curve shows the relation between (P_r) and (n)

- $L = 20$ mm [0.78 in]

COPPIE DI SERRAGGIO TIGHTENING TORQUE

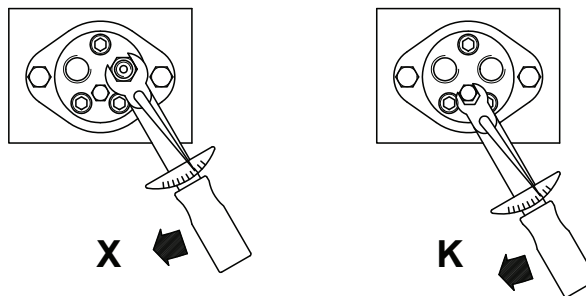

	X	K
Raccordi - Nipples	3/8 G (BSPP)	1/8 G (BSPP)
con rondella in acciaio - with steel washer	60 Nm 44.2 [lbf·ft]	20 Nm 14.7 [lbf·ft]
con rondella in alluminio - with aluminium washer	40 Nm 29.4 [lbf·ft]	10 Nm 7.3 [lbf·ft]
con rondella in rame - with copper washer	60 Nm 44.2 [lbf·ft]	20 Nm 14.7 [lbf·ft]

BGM 013

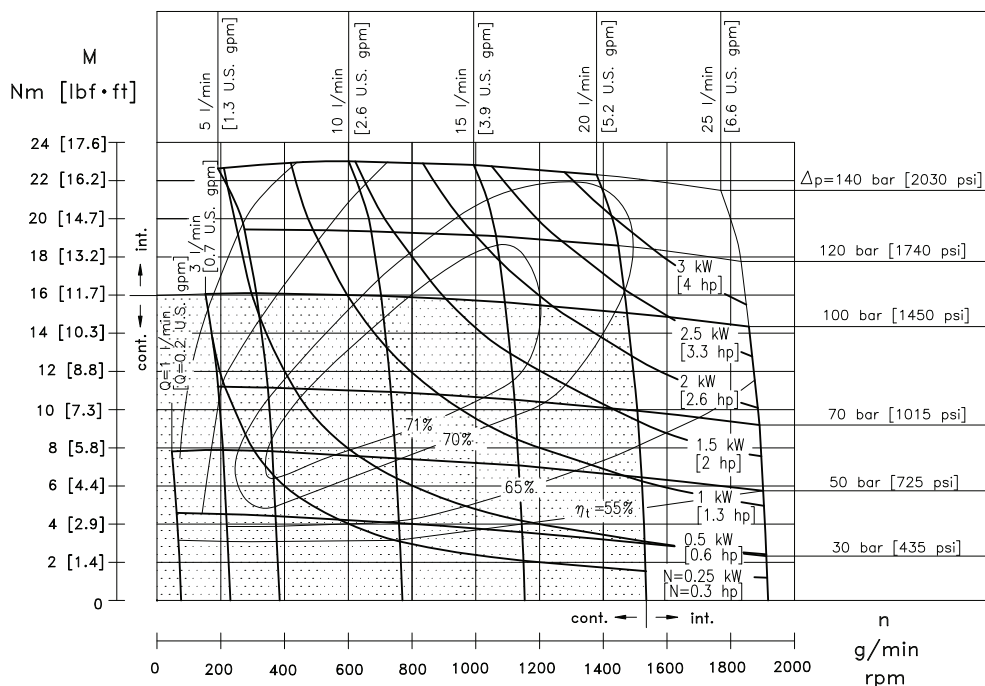

Pressioni e portate superiori a quelle ammesse in regime continuo non devono essere applicate contemporaneamente.
Exceeding continuous pressure values or exceeding flow values indicated, must not occur simultaneously.

BGM 020

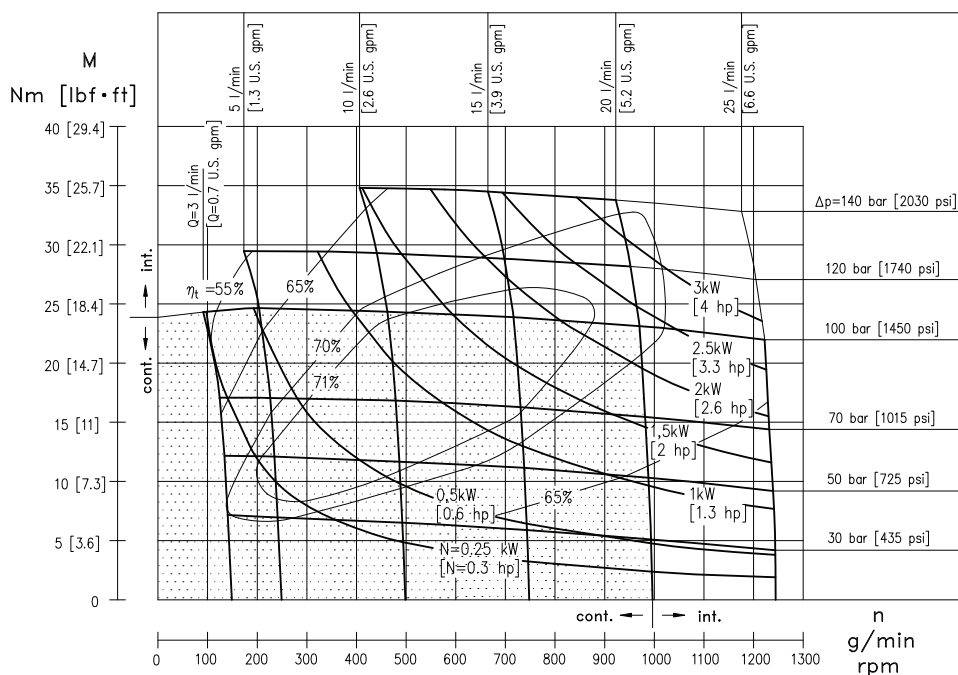

Pressioni e portate superiori a quelle ammesse in regime continuo non devono essere applicate contemporaneamente.
Exceeding continuous pressure values or exceeding flow values indicated, must not occur simultaneously.

BGM 032

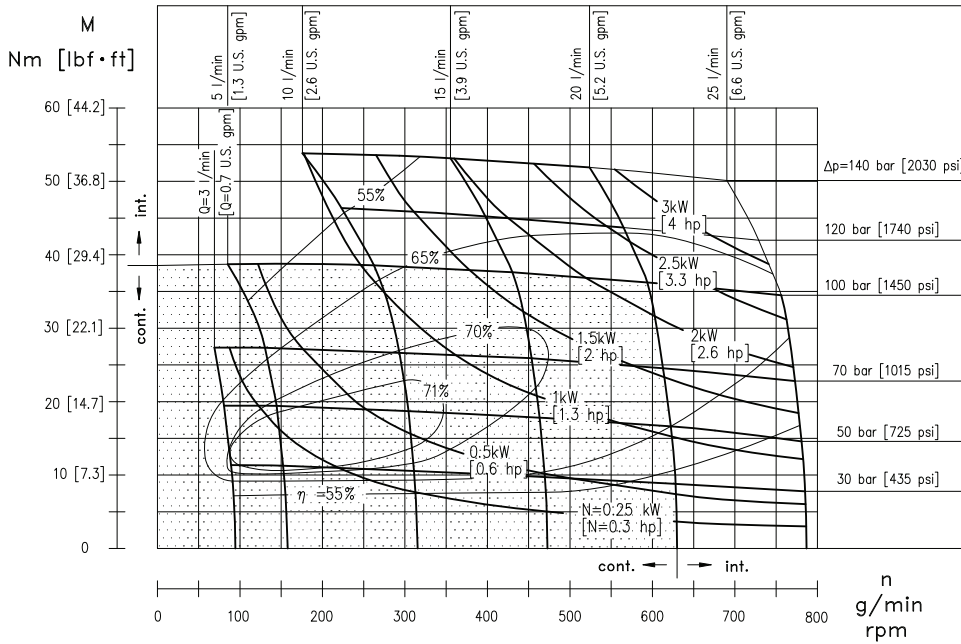

Pressioni e portate superiori a quelle ammesse in regime continuo non devono essere applicate contemporaneamente.
Exceeding continuous pressure values or exceeding flow values indicated, must not occur simultaneously.

BGM 040

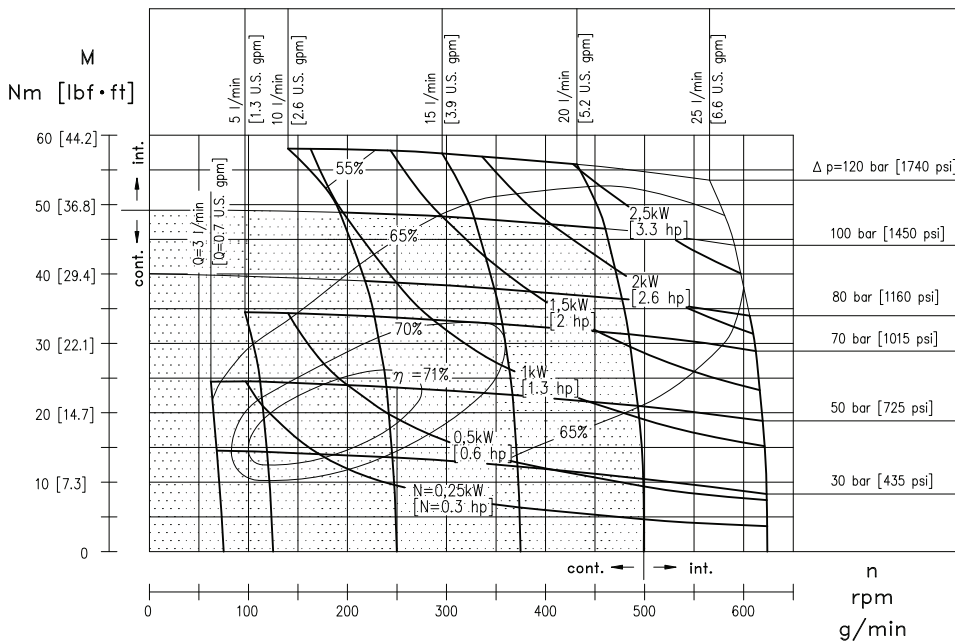

Pressioni e portate superiori a quelle ammesse in regime continuo non devono essere applicate contemporaneamente.
Exceeding continuous pressure values or exceeding flow values indicated, must not occur simultaneously.

BGM 050

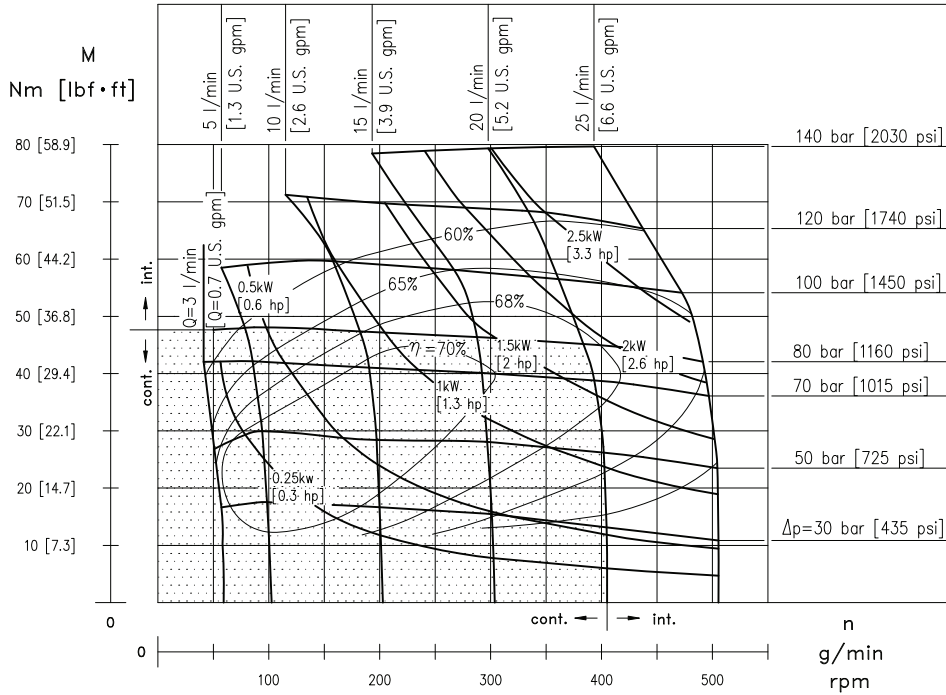

Pressioni e portate superiori a quelle ammesse in regime continuo non devono essere applicate contemporaneamente.
Exceeding continuous pressure values or exceeding flow values indicated, must not occur simultaneously.

Informazioni sul prodotto

Dati i continui sviluppi, le modifiche e le migliorie al prodotto, la S.A.M. Hydraulik Spa non sarà responsabile per eventuali informazioni che possano indurre in errore, od erronee, riportate da cataloghi, istruzioni, disegni, dati tecnici e altri dati forniti dalla S.A.M. Hydraulik Spa. Non sarà possibile basare alcun procedimento legale su tale materiale.

Modifiche del prodotto. La S.A.M. Hydraulik Spa si riserva il diritto di variare i suoi prodotti, anche quelli già ordinati, senza notifica.

Notice

Due to the continuous product developments, modifications and improvements S.A.M. Hydraulik Spa will not be held responsible for any erroneous information or data that may lead to errors, indicated in catalogues, instructions, drawings, technical data and other data supplied by S.A.M. Hydraulik Spa. Therefore, legal actions cannot be based on such material. **Product development.** S.A.M. Hydraulik Spa reserves the right to make changes to its products, even for those already ordered, without notice.
