

Radial piston motor for hydraulic drive assist

MCR-R

Series 41

RE 15223

Edition: 03.2017

Replace 07.2015



- ▶ Frame size MCR 10
- ▶ Displacement 780cc and 1120cc
- ▶ Differential pressure up to 450 bar
- ▶ Torque output up to 6420 Nm
- ▶ Drive speed up to 215 rpm
- ▶ Freewheel speed up to 600 rpm
- ▶ Open and closed circuits

Features

- ▶ Compact robust construction
- ▶ Rotating case design
- ▶ High volumetric and mechanical efficiencies
- ▶ High pressure rating
- ▶ High reliability
- ▶ Low maintenance
- ▶ Smooth running at very low speeds
- ▶ Low noise
- ▶ Integrated flushing in drive and freewheel

Contents

| | |
|------------------------|---|
| Functional description | 2 |
| Ordering code | 4 |
| Technical data | 5 |
| Dimensions | 7 |
| Selection guide | 8 |

Functional description

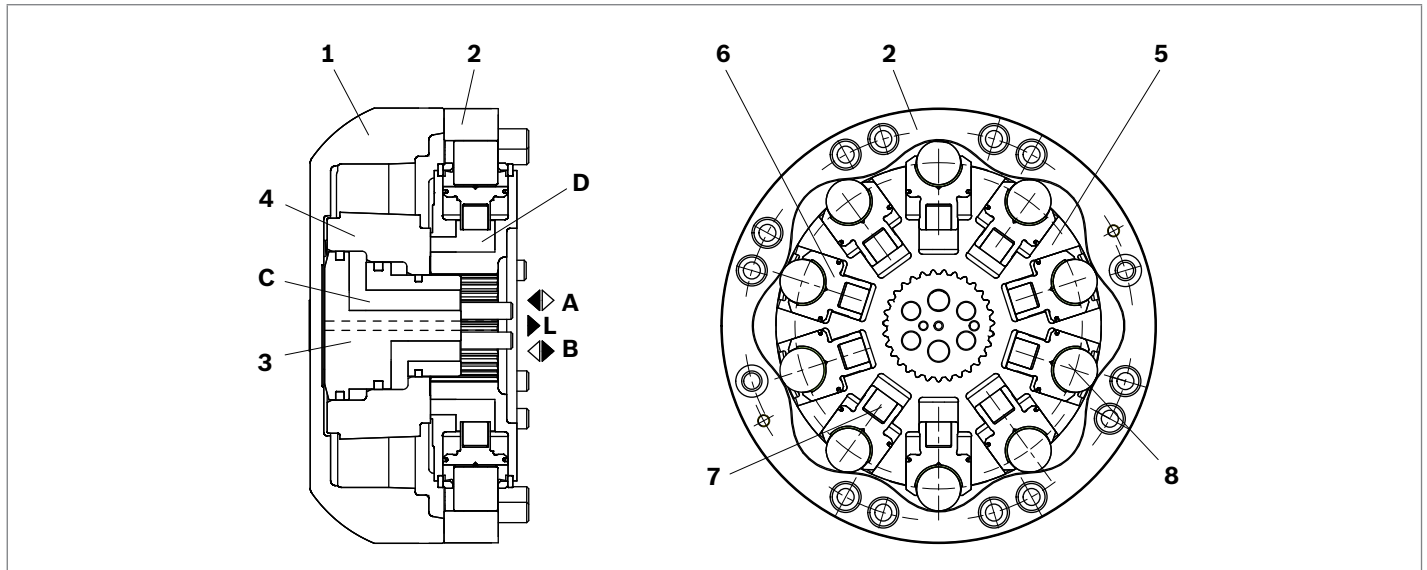

Hydraulic motor type MCR-R is a radial piston motor with a rotating case designed for installation on a vehicle axle to provide hydraulic drive to its wheel.

Construction

Rotating assembly consisting of case (1), cam (2) and distributor (4). Cylinder block (5) containing pistons (6) fitted with magnets (7). Fixed stub axle extension (3).

Transmission

The cylinder block (5) is splined onto the vehicle's axle. The pistons (6) are arranged radially in the cylinder block (5) and make contact with the cam (2) via rollers (8). The extension of the pistons (6) acting upon the cam (2) drives the rotating assembly which is bolted to the vehicle's wheel hub.

Torque generation

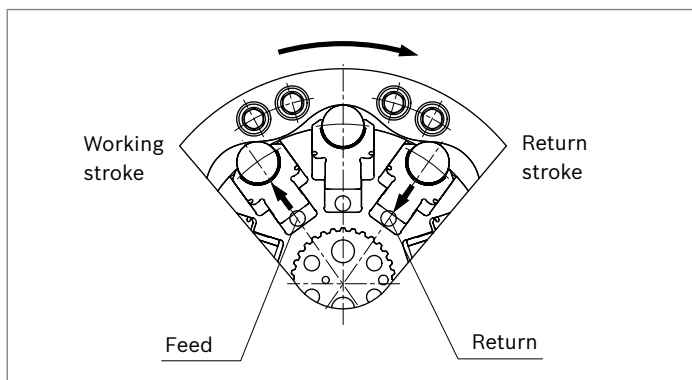

The number of working and return strokes corresponds to the number of lobes on the cam multiplied by number of pistons in the cylinder block.

Flow paths

Ports **A**, **B** and **L** are connected to galleries drilled through the vehicle axle. The galleries in the stub axle extension (**C**) direct the oil via the distributor (**4**) into the cylinder chambers (**D**). The **L** port returns leakage oil from the motor case.

Freewheeling

When not in drive mode the motor is selected to freewheel by relieving ports **A** and **B** to tank and pressurising the case via port **L**. This pushes the pistons back into the cylinder block and holds the rollers clear of the cam. In the event of loss of hydraulic pressure the magnets in the base of each piston (**7**) will hold them in the retracted position.

Motor flushing

In a closed circuit hydraulic system, the same fluid circulates between the pump and the motor. If the system was run under these conditions for any length of time the fluid would soon overheat. To address this the MCR-R has an integral flushing system which allows a controlled flow of fluid to be diverted from the system and back to tank via the system cooling arrangement.

The MCR-R includes features to enable integral flushing in both drive and freewheel modes, flushing during freewheel is of particular importance due to the higher operating speeds.

Flushing during drive

Pressure differential between **A** and **B** will cause the flushing spool (1) to shift and connect the low pressure return flow to the flushing poppet (2). If the return pressure is above a predetermined level the flushing poppet will open and allow fluid flow to tank via the motor case drain (L). The standard setting for the poppet cut off is 14 bar. This is to protect other system functions by closing off flushing flow if system return (charge) pressure drops below this value. The flushing flow rate is determined by the flushing poppet orifice (3). Different sizes of orifice are available to vary the flow depending upon system requirements.

Flushing during freewheel

During freewheel, **A** and **B** ports are connected to tank and a fluid flow is applied to the **L** port to pressurise the motor's case and push the pistons back into the cylinder block. Poppets (4) will open and permit fluid flow from the case back to tank via the **A** and **B** ports.

▼ **Motor with flushing valve**

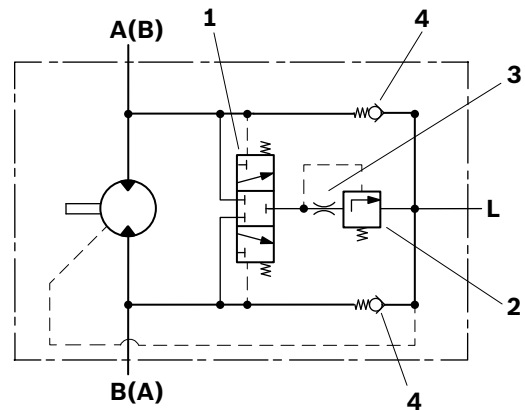

Flushing flow rates

| Flushing code | Orifice size (mm) | Flow (l/min) at 25 bar ¹⁾ | |
|---------------|-------------------|--------------------------------------|------|
| | | min | max |
| F1 | ø1 | 2.2 | 2.7 |
| F2 | ø1.5 | 5.0 | 6.1 |
| F7 | ø1.7 | 6.4 | 7.8 |
| F4 | ø2 | 8.2 | 10.7 |
| F6 | ø2.3 | 8.8 | 11.4 |

1) 0.6 mm Shim (Standard), Cracking pressure = 11±3 bar

4 **MCR-R Series 41** | Radial piston motor
Ordering code

Ordering code

| | | | | | | | | | | | | |
|------------|-----------|----------|----|----------|----------|----------|-----------|-----------|----|-----------|----|----|
| 01 | 02 | 03 | 04 | 05 | 06 | 07 | 08 | 09 | 10 | 11 | 12 | 13 |
| MCR | 10 | R | | Z | Z | / | 41 | A0 | | 1L | | |

Radial piston motor

| | | |
|----|--|------------|
| 01 | Radial-piston type, low-speed, high-torque motor | MCR |
|----|--|------------|

Frame size

| | | |
|----|---------------|-----------|
| 02 | Frame size 10 | 10 |
|----|---------------|-----------|

Housing type

| | | |
|----|-------------------------|----------|
| 03 | Rotating case hydrobase | R |
|----|-------------------------|----------|

Nominal size, displacement V_g in cm^3/rev

| | | | | |
|----|---|----|------------|-------------|
| 04 | Frame size 10 | | 780 | 1120 |
| | Low displacement: motors use standard cylindrical pistons | LD | ● | - |
| | High displacement: motors use stepped pistons | HD | - | ● |

Drive shaft

| | | |
|----|---------------------|----------|
| 05 | Without drive shaft | Z |
|----|---------------------|----------|

Through shaft

| | | |
|----|-----------------------|----------|
| 06 | Without through shaft | Z |
|----|-----------------------|----------|

Series

| | | |
|----|-----------|-----------|
| 07 | Series 41 | 41 |
|----|-----------|-----------|

Brake

| | | |
|----|---------------|-----------|
| 08 | Without brake | A0 |
|----|---------------|-----------|

Seals

| | | |
|----|-----------------------|----------|
| 09 | NBR (nitrile rubber) | M |
| | FKM (fluoroelastomer) | V |

Direction of rotation

| | | |
|----|---|-----------|
| 10 | Viewed from inboard end of stub axle extension, clockwise with flow into port A | 1L |
|----|---|-----------|

Flushing

| | | |
|----|-------------------------------------|--------------|
| 11 | Without flushing (no code) | |
| | With flushing (see table on page 3) | F1-F7 |

Special order

| | | |
|----|-----------------|--------------|
| 12 | Special feature | SOXXX |
|----|-----------------|--------------|

Other

| | | |
|----|-------------------|---|
| 13 | Mark in text here | * |
|----|-------------------|---|

● = Available - = Not available

Technical data

| Frame size | | | MCR10R | |
|---|---------------------------|----------------------|------------|------|
| Type of mounting | Hydrobase - rotating case | | | |
| Pipe connections ¹⁾²⁾ | Integral to stub axle | | | |
| Displacement | V_g | cm ³ /rev | 780 | 1120 |
| Output torque | | | | |
| Specific torque (at $\Delta p = 250$ bar) | | Nm | 3100 | 4520 |
| Maximum torque ³⁾ | T_{max} | Nm | 5580 | 6420 |
| Output speed | | | | |
| Minimum speed for smooth running ⁴⁾ | n_{min} | rpm | 0.5 | 0.5 |
| Maximum speed ⁵⁾⁶⁾ | n_{max} | rpm | 215 | 150 |
| Maximum freewheel speed ¹⁰⁾ | | rpm | 600 | 600 |
| Pressure | | | | |
| Maximum differential pressure ³⁾⁷⁾ | Δp_{max} | bar | 450 | 400 |
| Maximum pressure at port "A" or "B" ³⁾⁷⁾ | p_{max} | bar | 470 | 420 |
| Maximum case drain pressure | $p_{case\ max}$ | bar | 10 | 10 |
| Operating case pressure | $p_{case\ nom}$ | bar | 5 | 5 |
| Weight | m | kg | 30 | 30 |
| Hydraulic fluid ⁸⁾ | | | | |
| Fluid cleanliness | ISO 4406, Class 20/18/15 | | | |
| Fluid viscosity range | $\nu_{min/max}$ | mm ² /s | 10 to 2000 | |
| Fluid temperature range ⁹⁾ | $\theta_{min/max}$ | °C | -20 to +85 | |

Notice

- ▶ Motor performance values are based on theoretical calculations.
- ▶ Efficiencies are not taken into consideration for theoretical calculations.

Please refer the related foot notes for more details.

1) Ensure motor case is filled with oil prior to start-up.

2) For installation and maintenance details, please see operating manual 15215-01-B

3) Maximum values should only be applied for a small portion of the duty cycle. Please consult Rexroth Engineering, Department in Glenrothes for motor life calculations based on particular operating cases.

4) For continuous operation at speeds <5 rpm please consult Rexroth Engineering Department in Glenrothes.

5) Based on nominal no-load DP of 20 bar

6) Warning! During the running in period of the motor (min. 20 hrs) it should not be run unloaded at >100 rpm.

7) If planning to operate motors in series, please consult Rexroth Engineering Department in Glenrothes.

8) For any other fluid type contact the Engineering Department at Bosch Rexroth, Glenrothes. For more information on hydraulic fluids, see datasheets 90220 and 90223.

9) Extension of the allowable temperature range may be possible depending on specification. Please consult Rexroth Engineering Department in Glenrothes for further details.

10) For limited time speeds up to 720 rpm may be acceptable. Please consult Rexroth Engineering at Glenrothes.

Efficiencies

Data applies after a 20 hour run in time and has been established using a typical axle bearing arrangement.

▼ **Mechanical efficiency**

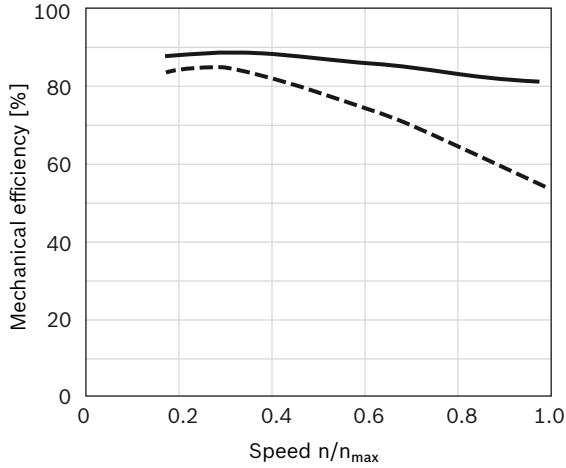

▼ **Volumetric efficiency**

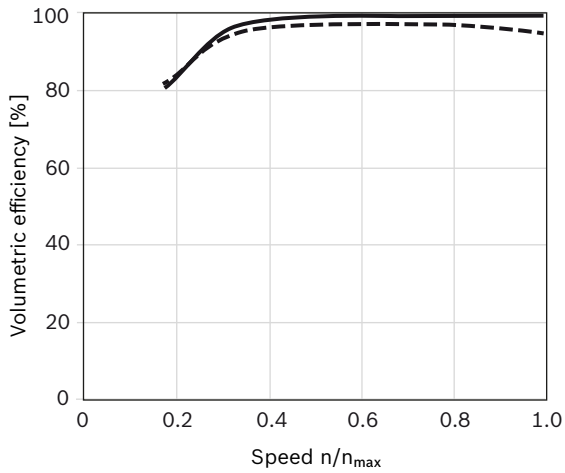

— 100 bar / 1450 psi
 - - - 350 bar / 5100 psi

Minimum charge pressure

Value is based on the requirement at the motor stub axle port.

▼ **Minimum charge pressure in pump mode**

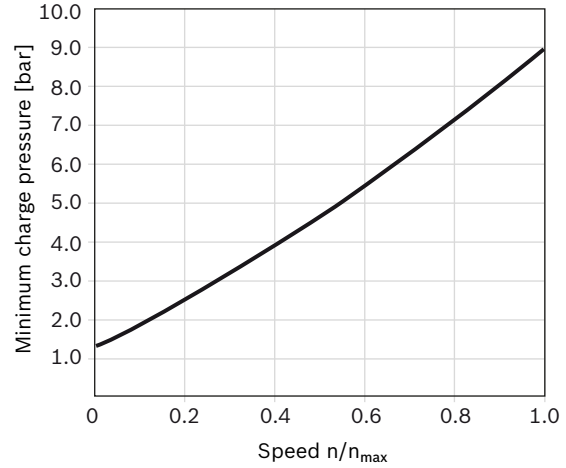

For specific performance information or operating conditions contact the Engineering Department at Bosch Rexroth Glenrothes.

Dimensions

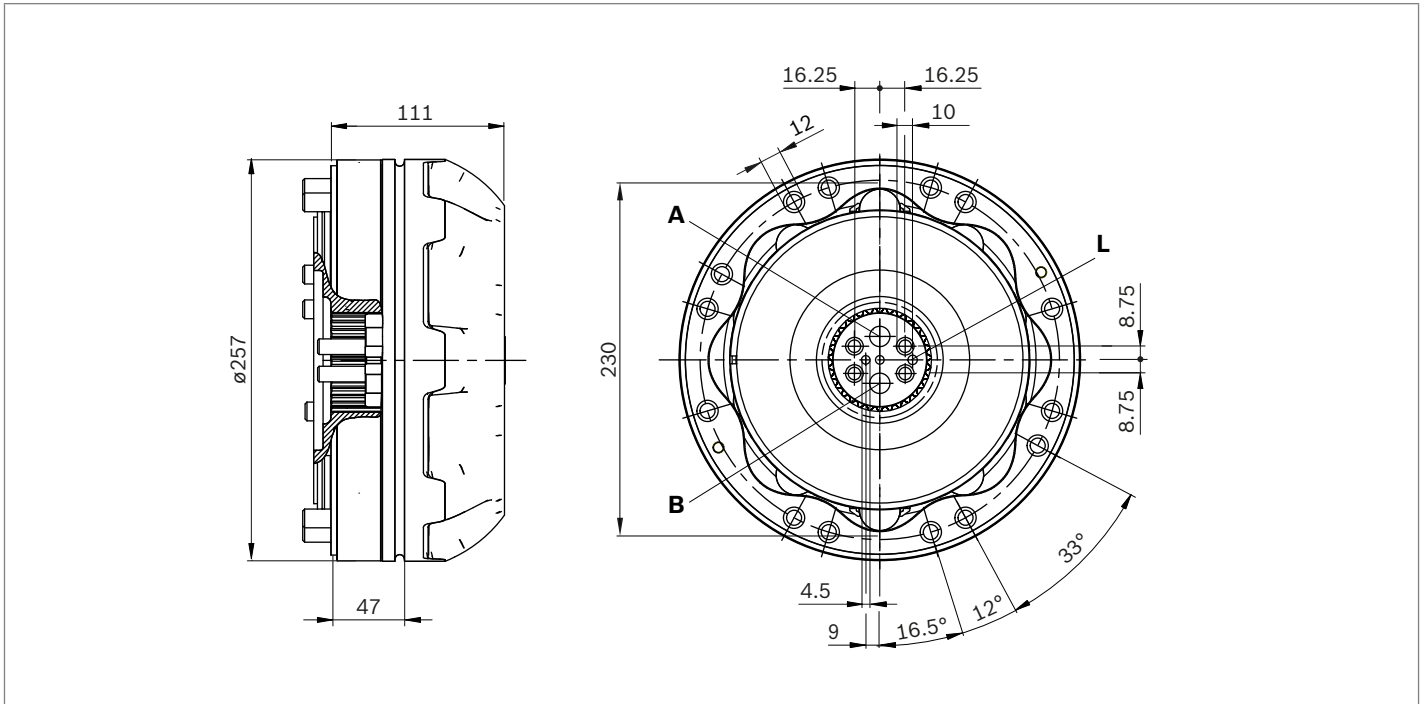

Ports

| Designation | Port function | Size | p_{max} [bar] | State ²⁾ |
|-------------|---------------|------------------|-----------------------|---------------------|
| A, B | Inlet, outlet | $\varnothing 12$ | 470/420 ¹⁾ | O |
| L | Case drain | $\varnothing 5$ | 10 | O |









1) Depending upon displacement

2) O = Must be connected (plugged on delivery)

X = Plugged (in normal operation)

Before finalizing your design, request a binding installation drawing.

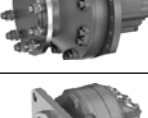
Selection guide

| Data sheet | Motor type Application | | Frame size | | | | | |
|------------|--|---|------------------|------------------|------------------|--------------------|---------------------|---------------------|
| | | | 3 160..400 cc | 5 380..820 cc | 6 820..920 cc | 10 780..1340 cc | 15 1130..2150 cc | 20 1750..3000 cc |
| 15198 | MCR-F Wheel drives |  | • | • | - | • | • | - |
| 15200 | MCR-W Heavy duty wheel drives |  | • | • | - | • | - | - |
| 15195 | MCR-A Frame integrated drives |  | • | • | - | • | • | - |
| 15199 | MCR-H Integrated drives |  | • | • | - | • | • | • |
| 15221 | MCR-T Track drives |  | - | • | • | • | - | - |
| 15223 | MCR-R Series 41 Hydraulic drive assist |  | - | - | - | • | - | - |
| 15214 | MCR-X Slew drives |  | • | • | - | - | - | - |
| 15197 | MCR-C Compact drives |  | - | - | - | - | - | • |
| 15196 | MCR-D Industrial applications |  | • | • | - | • | - | - |
| | MCR-E Industrial applications |  | - | • | - | - | - | - |

Bosch Rexroth Limited
Viewfield Industrial Estate
Glenrothes, Fife
Scotland, KY6 2RD
UK
Phone +44 15 92 631 777
Telefax +44 15 92 631 936
www.boschrexroth.com

© Bosch Rexroth AG 2017. All rights reserved, also regarding any disposal, exploitation, reproduction, editing, distribution, as well as in the event of applications for industrial property rights. The data specified within only serves to describe the product. No statements concerning a certain condition or suitability for a certain application can be derived from our information. The information given does not release the user from the obligation of own judgment and verification. It must be remembered that our products are subject to a natural process of wear and aging.